

BOLLARD - REMOVABLE: PLAN

SCALE: 1-1/2"=1'-0"

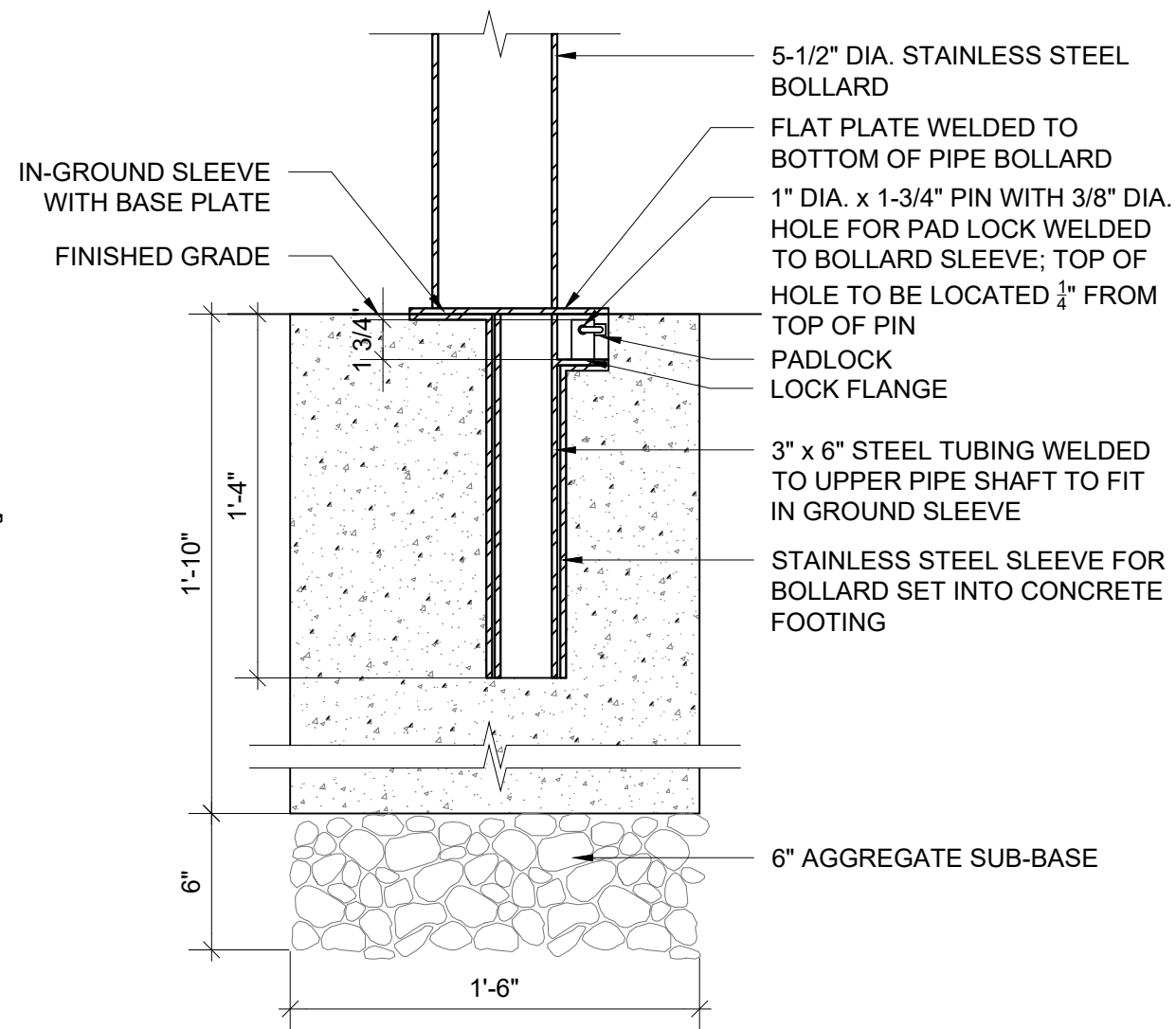

STAINLESS STEEL BOLLARD - REMOVABLE: SECTION - B

SCALE: 1-1/2"=1'-0"

NOTES

1. PIPE BOLLARD, TOP AND FLANGES TO BE STEEL. BOLLARD SHAFT 16" BELOW GRADE.
2. IN-GROUND SLEEVE TO BE STAINLESS STEEL SET IN CONCRETE FOOTING 30" BELOW GRADE.
3. ALL PARTS WELDED AND GROUND SMOOTH.

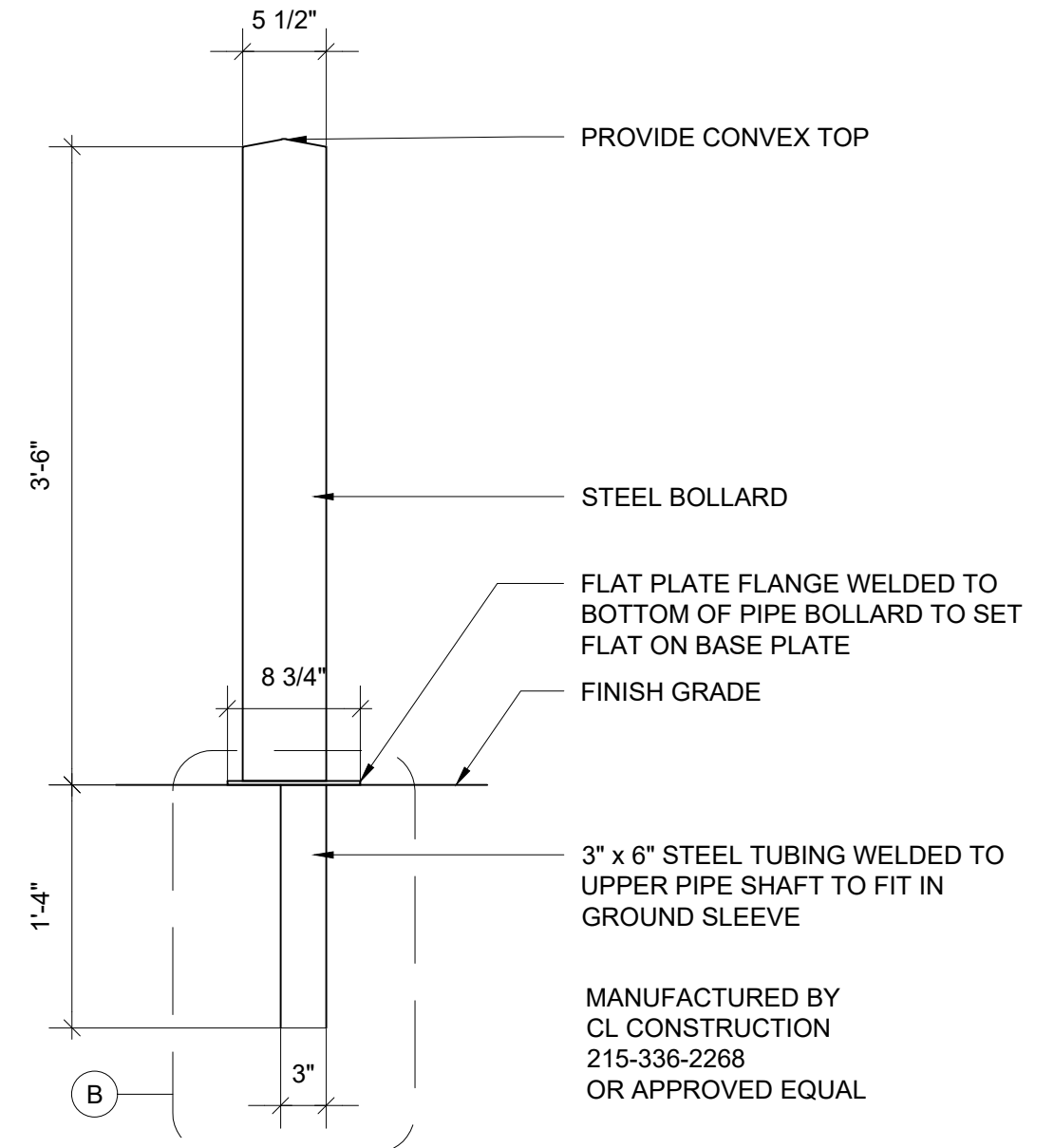

STAINLESS STEEL BOLLARD - REMOVABLE: SECTION - A

SCALE: 1"=1'-0"

MANUFACTURED BY
CL CONSTRUCTION
215-336-2268
OR APPROVED EQUAL

**STAINLESS STEEL BOLLARD -
REMOVABLE: ISOMETRIC**

SCALE: 1-1/2"=1'-0"

CSI 32 39 13 - 2

STAINLESS STEEL BOLLARD - REMOVABLE
LANDSCAPE STANDARDS



PRIOR TO CONSTRUCTION, CONFIRM LAYOUT, DIMENSIONS,
ADJACENT UTILITIES AND FINAL MATERIALS WITH U OF P
OFFICE OF THE UNIVERSITY ARCHITECT. THIS DETAIL TO BE
USED AS A GUIDE ONLY. SPECIFIC REVISIONS FOR SITE
CONDITIONS AND INTENT ARE THE RESPONSIBILITY OF THE
INDIVIDUAL PROJECT DESIGNER.

Facilities & Real Estate Services
Office of the University Architect
2024