

BICYCLE RACKS ON RAILS: SECTION

SCALE: 3/4"=1'-0"

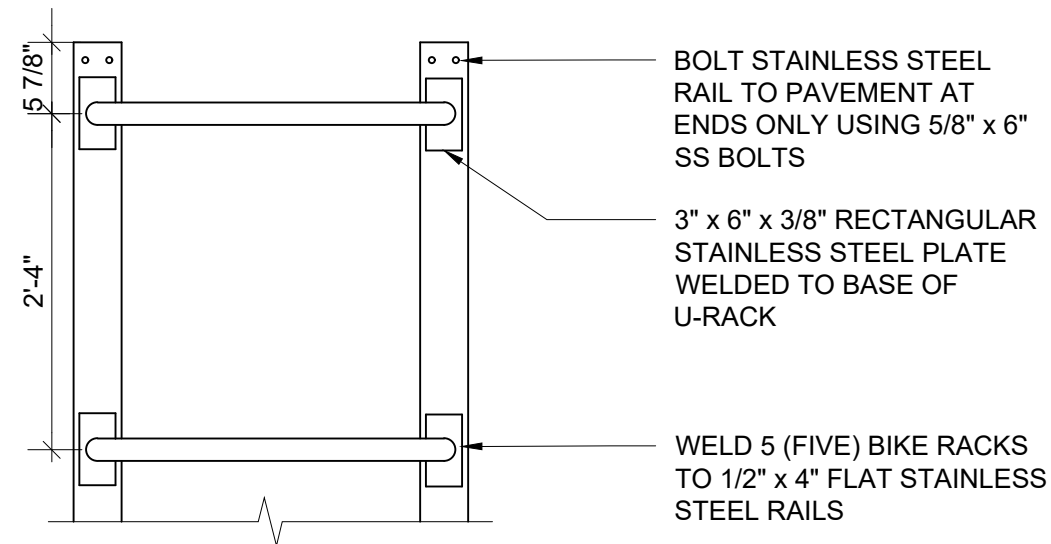

BICYCLE RACKS ON RAILS: PLAN

SCALE: 3/4"=1'-0"

**MANUFACTURER**

1. OPTION 1: CUSTOM STAINLESS STEEL 'U' RACK AS FABRICATED BY C.F. MOORES COMPANY, OR EQUAL.
2. OPTION 2: MODEL UX238-U, STAINLESS STEEL AS FABRICATED BY MADRAX DIVISION, GRABER MANUFACTURING, OR EQUAL.

**NOTES**

1. PROVIDE 5 (FIVE) BIKE RACKS PER ASSEMBLY OR AS DIRECTED BY OFFICE OF THE UNIVERSITY ARCHITECT.
2. BIKE RACKS, HARDWARE, AND FASTENERS TO BE #316 MARINE GRADE STAINLESS STEEL.
3. ALL WELDS TO BE GROUND AND SMOOTH.
4. BOLT HEADS TO BE FLUSH WITH SURFACE OF RAIL.

**CSI 12 93 13 - 2**

**RAIL MOUNTED BICYCLE RACK**  
LANDSCAPE STANDARDS



PRIOR TO CONSTRUCTION, CONFIRM LAYOUT, DIMENSIONS, ADJACENT UTILITIES AND FINAL MATERIALS WITH U OF P OFFICE OF THE UNIVERSITY ARCHITECT. THIS DETAIL TO BE USED AS A GUIDE ONLY. SPECIFIC REVISIONS FOR SITE CONDITIONS AND INTENT ARE THE RESPONSIBILITY OF THE INDIVIDUAL PROJECT DESIGNER.

Facilities & Real Estate Services  
Office of the University Architect  
2022